

LENTON SPEED SLEEVE

COMPRESSION SPLICES

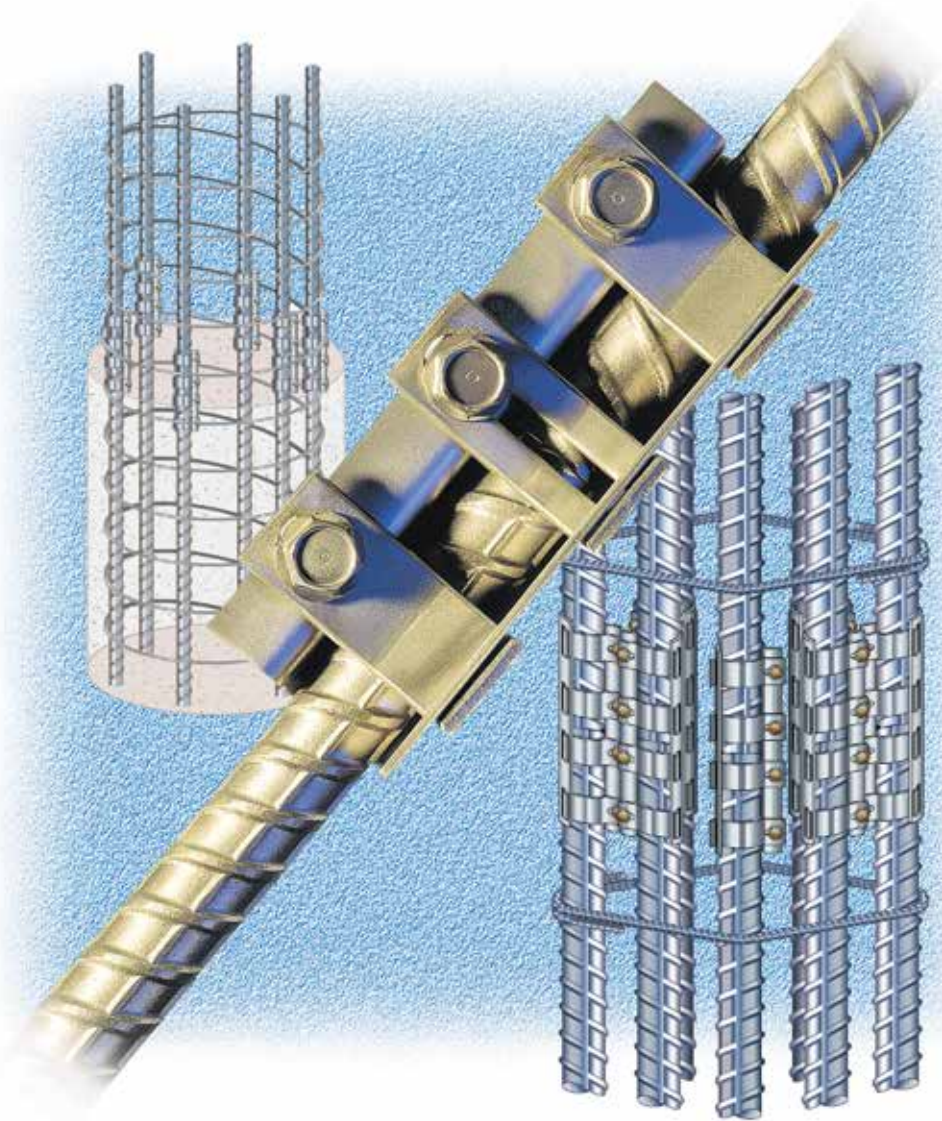

LENTON SPEED SLEEVE

For Ultimate Strength In Compression

The LENTON SPEED SLEEVE splice is a proven, quick and economical method of making compression splices for steel reinforced concrete construction projects all over the world.

LENTON SPEED SLEEVE splices comply with the requirements of many international reinforced concrete design codes such as DIN 1045, BS8110, ACI 318, AS 3600, IBC, ICC, UBC, CSA and others.

The LENTON SPEED SLEEVE is a simple and easy-to-install sleeve for holding square cut ends of bars in compression in concentric contact. The small dimensions of the sleeve generally eliminate the need for additional concrete cover on the reinforcement because the sleeve is typically thinner than the column stirrups.

LENTON SPEED SLEEVE Features:

- Easy to use – Requires only a small ratchet wrench to install. A power wrench reduces installation time even further (only 14-20 ft-lb torque required [19-27 Nm]).
- Self-supporting – Requires no “tack” welding.
- Fast – Installs in seconds. Speeds the installation of prefabricated cages since the sleeve can be installed on rebar dowels without the upper bar in place. Single person installation.
- Broad applicability – Works on bundled bars. Makes transition splices with the use of a simple adapter inserts.
- Removable and reusable – Can be easily removed and reused if necessary (contact Pentair for information).
- Forgiving – Compensates for rebar size variation and out of roundness.
- Secure – Positive end bearing is maintained without depending on the weight of the rebar to keep the ends in contact. Bars are individually secured, compensating for rebar size variations.



Ø 32 mm (#10) and smaller Ø 34 mm (#11) and larger

Bar End Preparation

1. Bar ends should be prepared by saw cutting or other means to provide a reasonably flat surface. Shear cutting may be used as long as they meet these requirements:
2. The ends of the bars must be within 1-1/2 degrees of square to the long axis. In field assembly, such splices when erected must fit within 3 degrees.

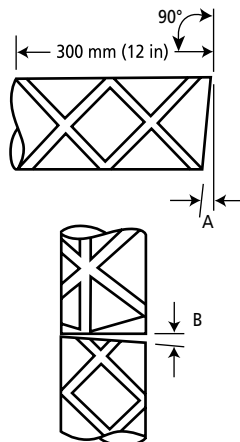

MAXIMUM END DEVIATION AND GAP Equivalent Linear Offsets*		
Rebar Size Max.	End Deviation 'A'	Maximum Gap 'B'
#18; 50-57 mm	0.06 in (1.6 mm)	0.12 in (3.0 mm)
#14; 40-43 mm	0.04 in (1.1 mm)	0.09 in (2.2 mm)
#11; 34-36 mm	0.04 in (0.9 mm)	0.07 in (1.8 mm)
#10; 30-32 mm	0.03 in (0.8 mm)	0.07 in (1.8 mm)
#9; 28 mm	0.03 in (0.7 mm)	0.06 in (1.4 mm)
#8; 25 mm	0.03 in (0.7 mm)	0.05 in (1.3 mm)
#7; 22 mm	0.02 in (0.6 mm)	0.05 in (1.2 mm)
#6; 20 mm	0.02 in (0.5 mm)	0.04 in (1.1 mm)

* = Tables are based on nominal bar diameters. Values are rounded
 * = Deviation and Gap based on ACI 318-08 Section 12.16.4

Note: Field adjustment or rotation of bar ends may be necessary to obtain a gap equal to or less than the Maximum Allowable Gap where Maximum Allowable Deviation exists on both bar ends.

Installation Procedure

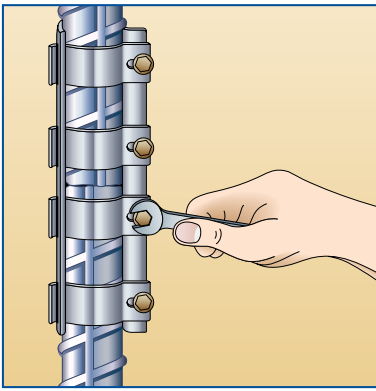

1. For rebar #11 (34 mm) and larger, place the LENTON SPEED SLEEVE over the bar end so that the end of the bar is between the middle two straps and tighten the lower bolts.

For rebar #10 (32 mm) and smaller, place the LENTON SPEED SLEEVE over the bar end so that the end of the bar is at the slot in the center strap and tighten only the bottom bolt. If required, place the adapter insert inside the sleeve. (See information below.)

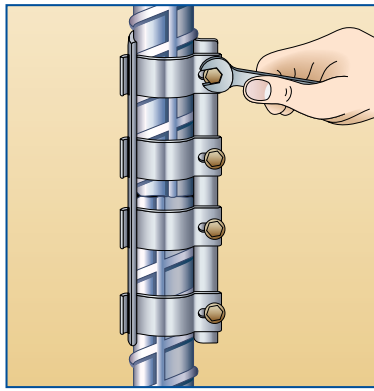

2. Insert the upper bar (and adapter inserts for transitions) so that it rests concentrically on the lower bar and tighten the upper two bolts.

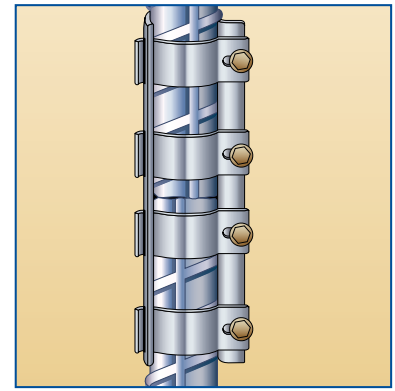

3. The bolts need to be tightened only enough to cause the straps to bend. The bolts do not need to be bottomed. Visual inspection is easy. A torque wrench is not required. Tightening can be done by hand since the installation only takes 14-20 ft-lb (19-27 Nm).

LENTON SPEED SLEEVE Ordering Information

Inch/Lb.	Bar Size Metric	Canadian Metric	Article Number	Part Number	Packing Unit
#6	20 mm	20 M	145495	RBW2686**	20
#7	22 mm	—	145500	RBW2687	20
#8	25 mm	25 M	145510	RBW2688	20
#9	28 mm	—	145520	RBW2689	20
—	30 mm	—	145530	—	20
#10	32 mm	30 M	145535	RBW26810	20
#11	34, 36 mm	35 M	145540	RBW26811	20
—	40 mm	—	145550	—	10
#14	43 mm	45 M	—	RBW26814	10
—	50 mm	—	145555	—	10
#18	57 mm	55 M	145560	RBW26818	10
Ratchet Wrench (Sizes: 22, 30, 34-36, 57)*			145570	RBW402	1

To Splice Bar Sizes Inch/Lb.	Bar Sizes		Use LENTON SPEED SLEEVE		Use Adapter Insert		No. Inserts Required Per Splice	Inserts Per Pkg.***
	Metric	Canadian Metric	Article Number	Part Number	Article Number	Part Number		
#8 to #7	25 to 22 mm	—	145510	RBW2688	—	RBW3997	1	20
#9 to #8	28 to 25 mm	—	145520	RBW2689	—	RBW3998	1	20
#10 to #9	32 to 28 mm	—	145535	RBW26810	145565	RBW3999	1	20
#11 to #10	36 to 32 mm	35 M to 30 M	—	RBW26811	—	RBW39910	1	20
#14 to #11	43 to 36 mm	45 M to 35 M	—	RBW26814	—	RBW39911	2	20
#18 to #14	57 to 43 mm	55 M to 45 M	145560	RBW26818	—	RBW39914	2	20

Please contact Pentair for more information regarding transition splices.

* Other LENTON SPEED SLEEVE sizes may contain metric bolts and can be tightened with standard metric tooling.

** #6 LENTON SPEED SLEEVE is not a stock item in North and South America. Call Pentair for availability.

*** Only complete packages shipped.

How To Specify

By Name: For compression-only splices, specify LENTON SPEED SLEEVE Compression-Only Splices.

By Generic Description: On jobs requiring a generic description (usually government specifications prohibit the use of a proprietary name), use the following description: Type of splice required is bolted sleeve to hold square-cut rebar ends in concentric contact for transmission of compression strength.



www.erico.pentair.com



AUSTRALIA
Phone 1-800-263-508
Fax 1-800-423-091

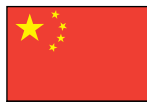

CHINA
Phone +86-21-3430-4878
Fax +86-21-5831-8177



HUNGARY
Phone 06-800-16538
Fax +39-0244-386-107



NORWAY
Phone 800-100-73
Fax 800-100-66



SWITZERLAND
Phone 0800-55-86-97
Fax 0800-55-96-15



BELGIUM
Phone 0800-757-48
Fax 0800-757-60



DENMARK
Phone 808-89-372
Fax 808-89-373



INDONESIA
Phone +62-21-575-0941
Fax +62-21-575-0942



POLAND
Phone +48-71-349-04-60
Fax +48-71-349-04-61



THAILAND
Phone +66-2-267-5776
Fax +66-2-636-6988



BRAZIL
Phone +55-11-3623-4333
Fax +55-11-3621-4066



FRANCE
Phone 0-800-901-793
Fax 0-800-902-024



ITALY
Phone 800-870-938
Fax 800-873-935



SINGAPORE
Phone +65-6-268-3433
Fax +65-6-268-1389



UNITED ARAB EMIRATES
Phone +971-4-881-7250
Fax +971-4-881-7270



CANADA
Phone +1-800-677-9089
Fax +1-800-677-8131



GERMANY
Phone 0-800-189-0272
Fax 0-800-189-0274



MEXICO
Phone +52-55-5260-5991
Fax +52-55-5260-3310



SPAIN
Phone 900-993-154
Fax 900-807-333



UNITED KINGDOM
Phone 0808-2344-670
Fax 0808-2344-676



CHILE
Phone +56-2-370-2908
Fax +56-2-369-5657



HONG KONG
Phone +852-2764-8808
Fax +852-2764-4486



NETHERLANDS
Phone 0800-0200-135
Fax 0800-0200-136



SWEDEN
Phone 020-790-908
Fax 020-798-964



UNITED STATES
Phone 1-800-753-9221
Fax +1-440-248-0723

WARNING

Pentair products shall be installed and used only as indicated in Pentair's product instruction sheets and training materials. Instruction sheets are available at www.erico.pentair.com and from your Pentair customer service representative. Improper installation, misuse, misapplication or other failure to completely follow Pentair's instructions and warnings may cause product malfunction, property damage, serious bodily injury and/or death, and void your warranty.